

# Inventor 2011

## Sheet Metal Parts

Elise Moss

---

This lesson reviews the following skills

- Assigning materials and thicknesses
- Creating a base flange
- Adding a flange
- Folding and unfolding
- Adding a cut
- Adding chamfers

1.  Start with a new part file.

2. Exit the sketch.



3.  Activate the Environment tab on the ribbon.

Select the **Convert** tool to convert the part to a sheet metal part.

*This also opens the sheet metal module.*

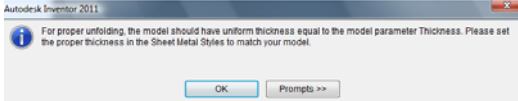
4.  Press **OK**.

5.  Select **Setup** from the ribbon.

*This allows you to define the material that will be used for the sheet metal part.*

# Inventor 2011

## Sheet Metal Parts

Elise Moss

6.  Set the Material Style to **Aluminum-6061**.  
Set the thickness to **.063 in**.  
Press **OK**.

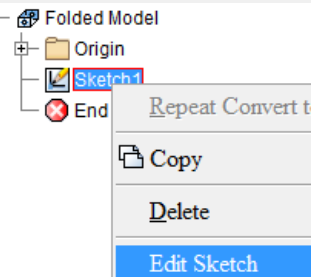
7.  Highlight the existing sketch.  
Right click and select **Edit Sketch**.

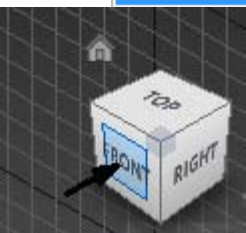
8.  Switch to a **Front** view using the viewcube.

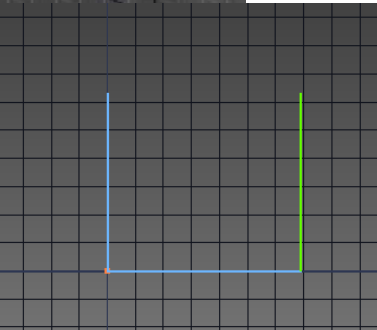
9.  Using the LINE tool, draw a U- shaped bracket.  
Place the left vertex so it is coincident with the center point.

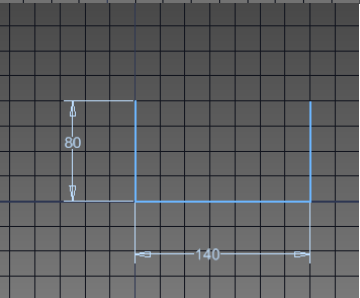
10.  Place the dimensions.  
Set the vertical lines as equal.

# Inventor 2011

## Sheet Metal Parts

Elise Moss

---

11. Exit the sketch.

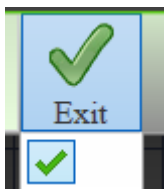

12. Select the **Contour Flange** tool from the Create panel.

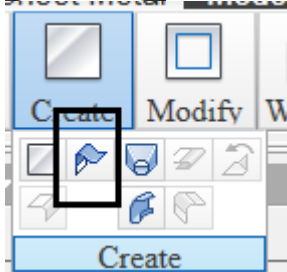

13. Select the sketch.

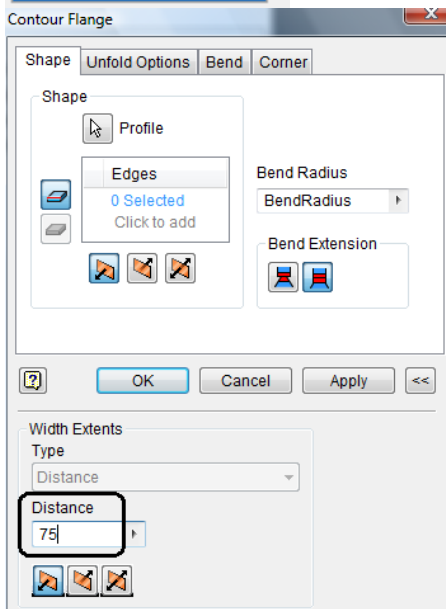

Set the Distance to **75 mm**.

Press **OK**.

14. Select the **Flange** tool.

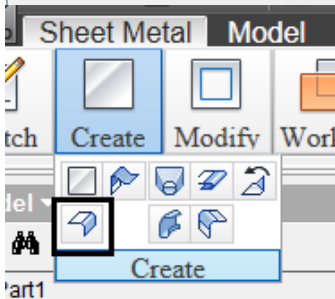

# Inventor 2011

## Sheet Metal Parts

Elise Moss

---

15.

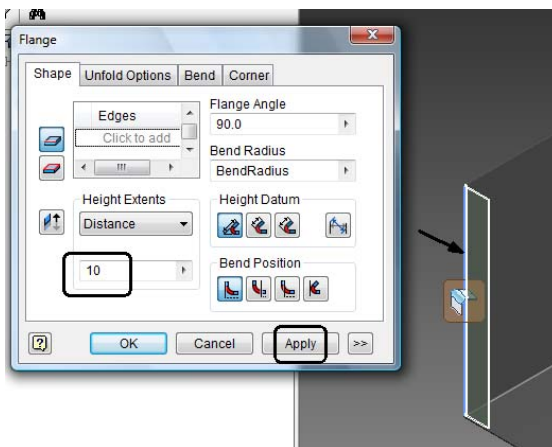

Select the edge.

Set the Distance to **10**.

Click **Apply**.

*Selecting Apply will keep the dialog open so you can select more edges.*

16.

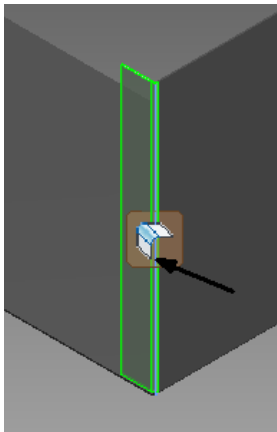

Add a 10 mm flange to the other side.

17.

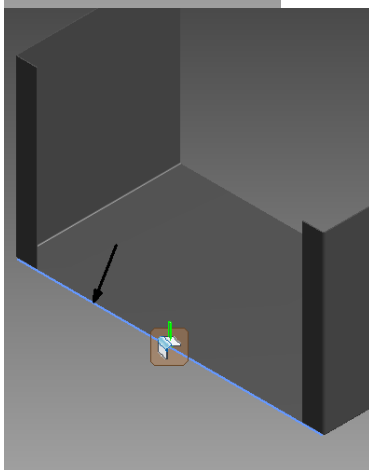

Select the bottom edge.

# Inventor 2011

## Sheet Metal Parts

Elise Moss

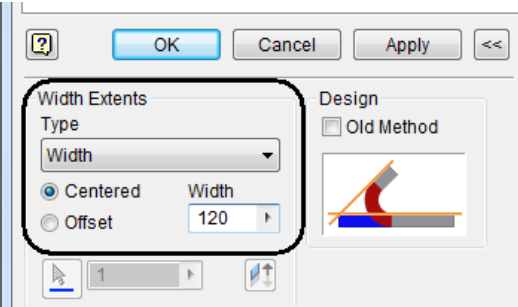
18.  Expand the bottom of the dialog.

Set the Type to **Width**.  
Enable **Centered**.  
Set the Width to **120**.

Press **OK**.

19.  Select the **Chamfer** tool from the Modify panel.

20.  Select the two edges indicated.

Set the Chamfer Distance to **5**.

Press **OK**.

21.  Select the front flange.

Select **Create Sketch**.

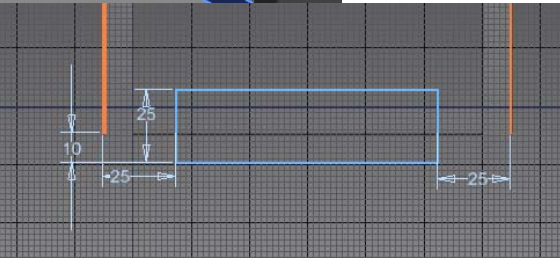
22.  Add dimensions so it is 25 mm from either side. Add a 10 mm vertical dimension below the bottom edge.

*The 10 mm is the distance into the part the cut will extend from the bended edge.*

# Inventor 2011

## Sheet Metal Parts

Elise Moss

---

23. Select the **Cut** tool on the Modify panel.

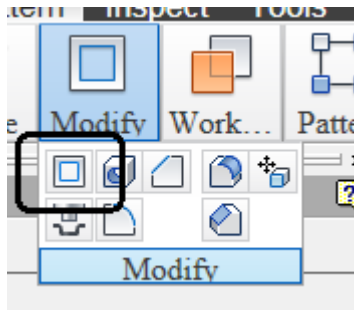

24. Enable **Cut Across Bend**.  
Press **OK**.

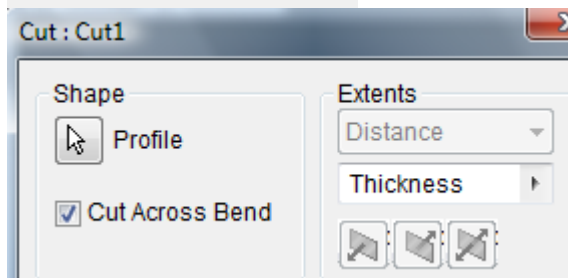

25. Notice how the bend extends into the part.

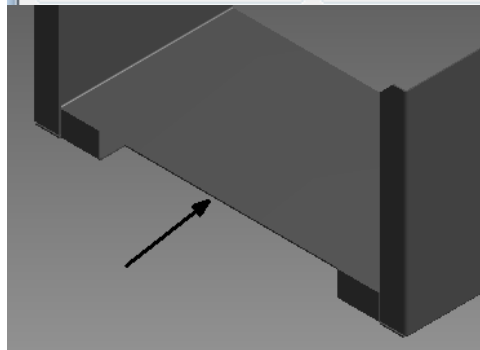

26. Select the **Flat Pattern** tool.

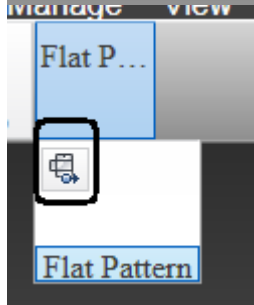

27. The sheet metal part unbends.

