

Going from 2D to 3D in Inventor 5.3

Elise Moss

## Going from 2D to 3D

Start by locating the 2D drawing you want to import.

The file used in this tutorial is called 'base.dwg'. You can download it [here](#).

The file was created in AutoCAD 2002.

Select 'Open' from the menu or toolbar.

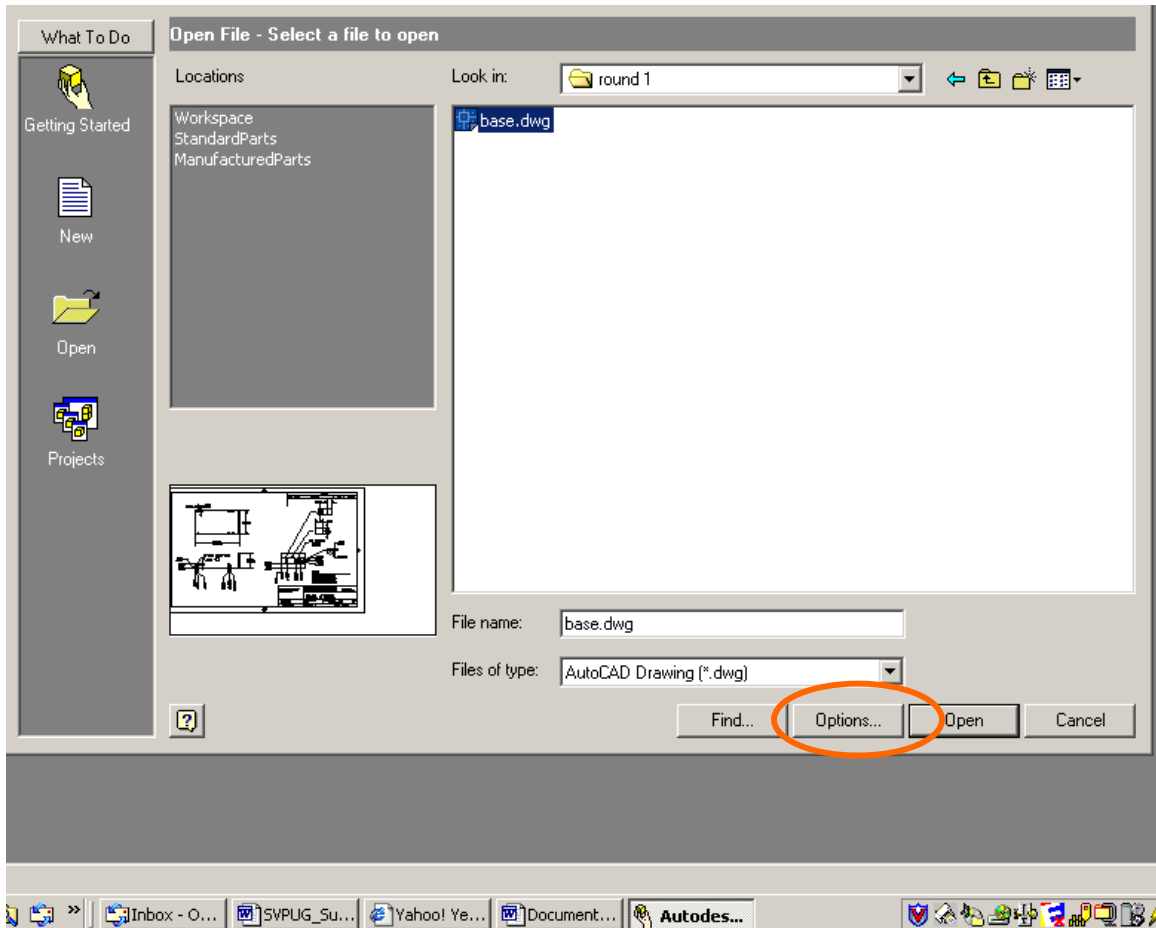

Highlight the file name and select 'Options'.

## Going from 2D to 3D in Inventor 5.3

Elise Moss

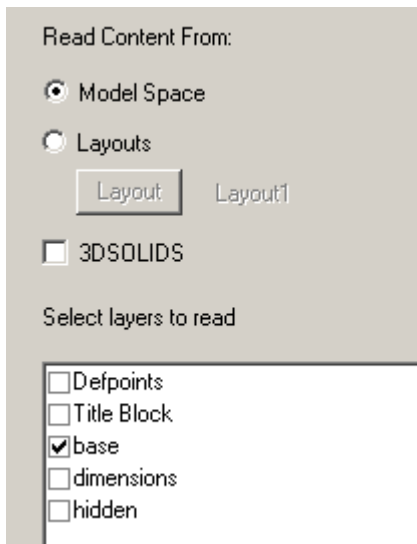
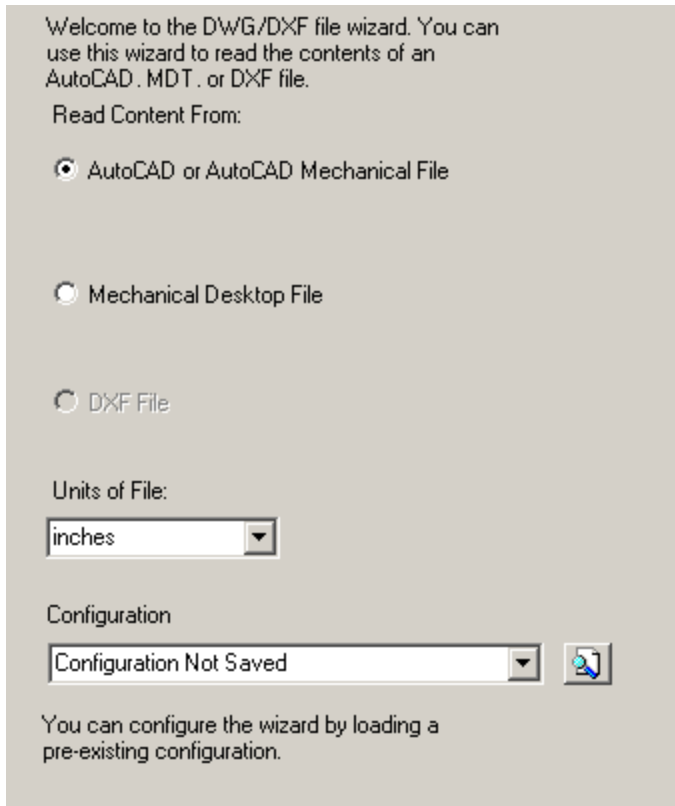

Set Read Content From to Model Space.

Select the 'base' layer to be imported.

You will see a preview of the layout in the view screen.

Press 'Next'.

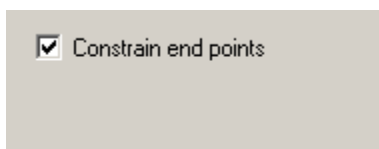

Enable 'Constrain end points' or you will have to run Sketch Doctor to add constraints before you will be able to extrude geometry.

## Going from 2D to 3D in Inventor 5.3

Elise Moss

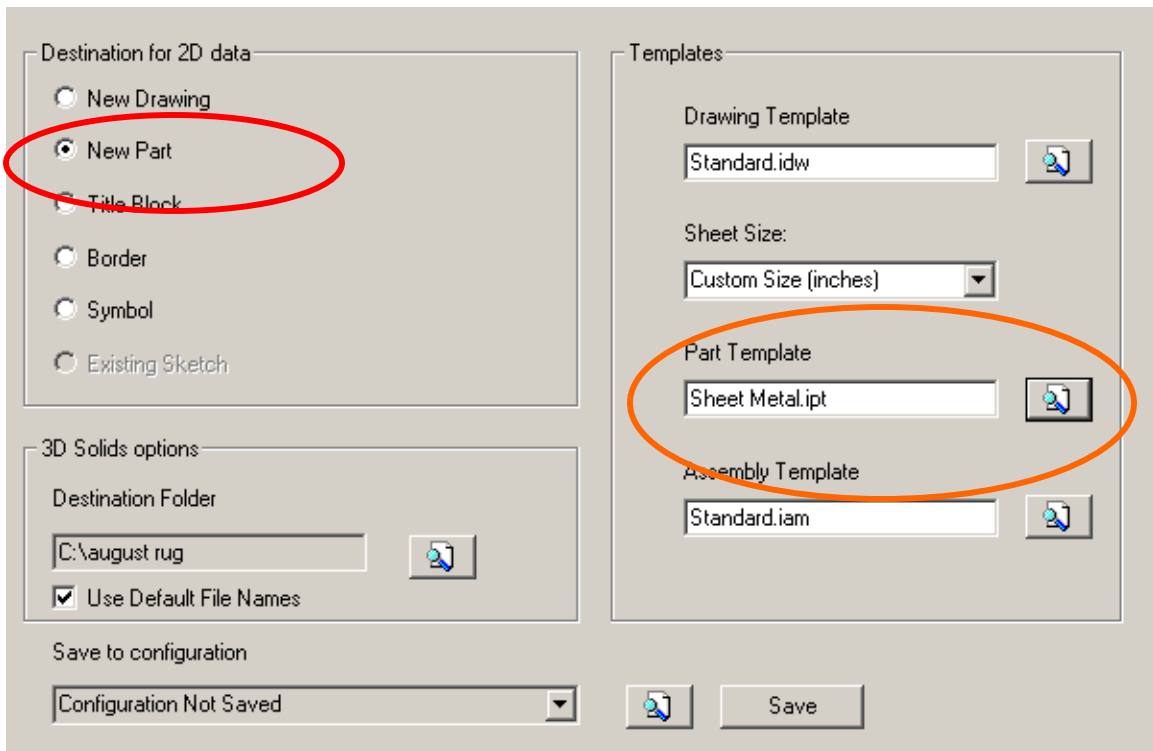

For Destination, select New Part.

For Part Template, select 'Sheet Metal'.

Press 'Finish'.

Press 'Open' to bring it into Inventor.

Zoom to Fit to see the sketch that you brought in.

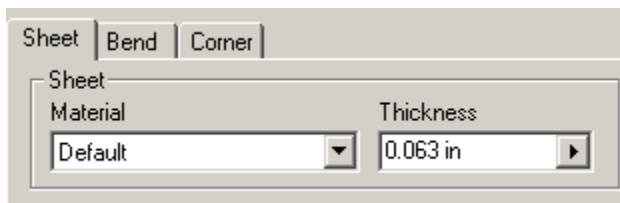

Go to Sheet Metal Settings and set the Thickness to 0.063.

Press 'Save' and 'Done'.

Activate the sketch.

## Going from 2D to 3D in Inventor 5.3

Elise Moss

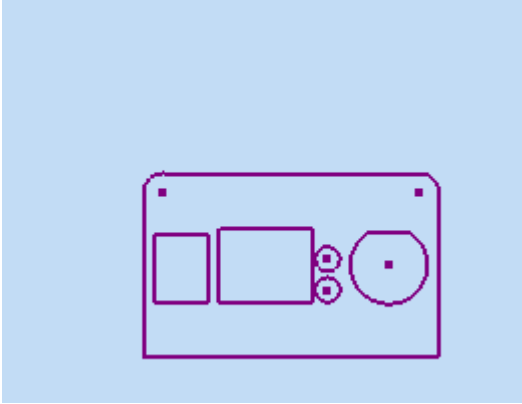

Window around just the front face of the sketch.

Right click and select 'Copy'.

Select the YZ Plane, select 'New Sketch' and 'Paste'.

Edit the 'New Sketch'.

Right click and select 'Sketch Doctor'.

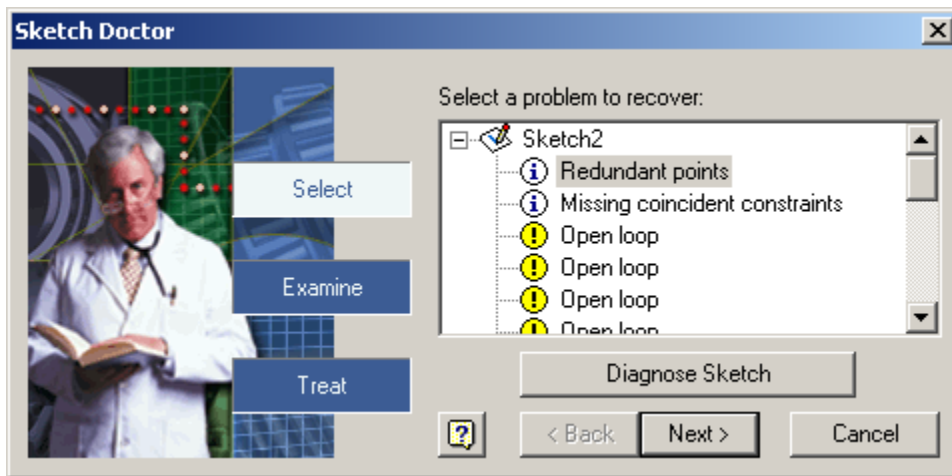

You will see there are some errors in the sketch due to the translation.

You can run through Sketch Doctor to heal the errors.

Once you close all the redundant points and missing coincident constraints, the open loops will be resolved. (This takes less than ten seconds to go through – do not get upset about it.)

## Going from 2D to 3D in Inventor 5.3

Elise Moss

Select the face tool and pick the profile.

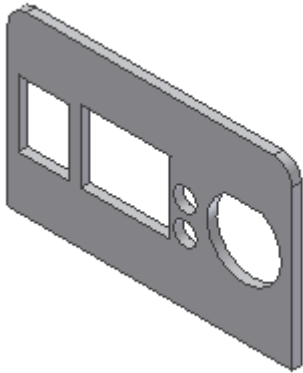

You have the first face.

Activate the first sketch and add a dimension to the length of the base.

Dimension the flanges.

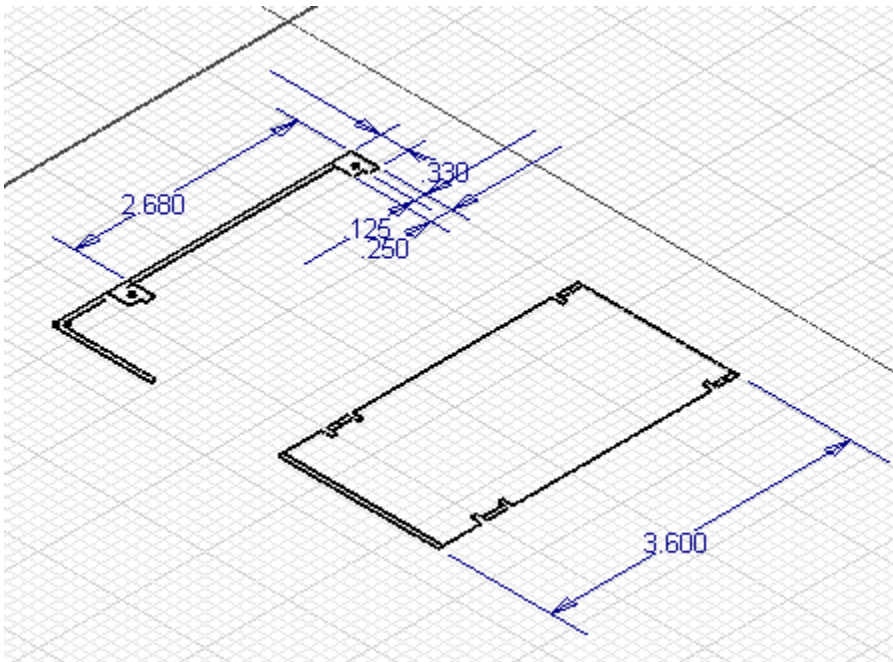

Exit the sketch, but keep it visible.



Select the flange tool.

## Going from 2D to 3D in Inventor 5.3

Elise Moss

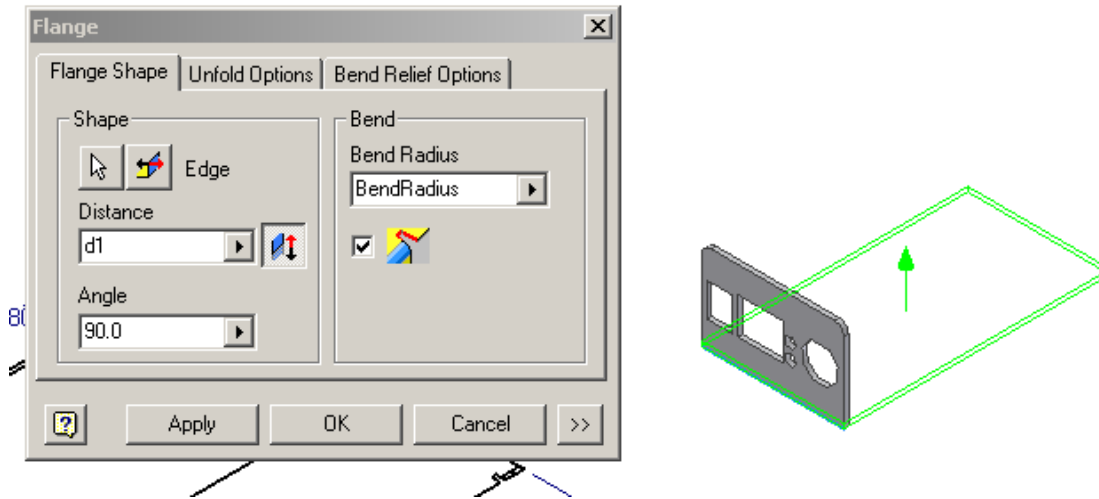

Select the front edge of the face.

For the distance, pick the length dimension you placed on the sketch.

Press 'Apply' and 'OK'.

Activate the first sketch again and copy the two flanges.

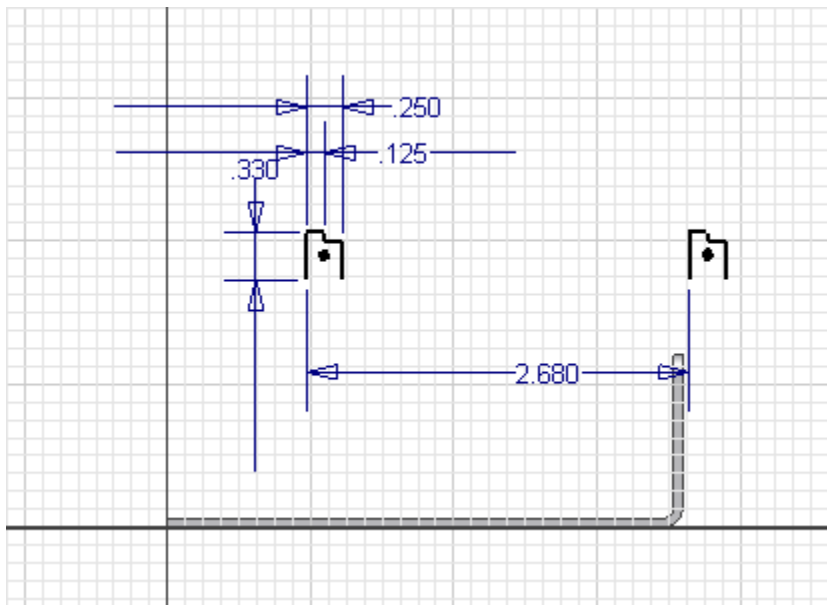

Paste the copied geometry onto a New Sketch located on the side of the part.



Use the Move tool to move the sketch onto the part correctly.

**HINT:** You need to project either the endpoint or end edge so you have something to align to when you move the sketch.

Going from 2D to 3D in Inventor 5.3  
Elise Moss

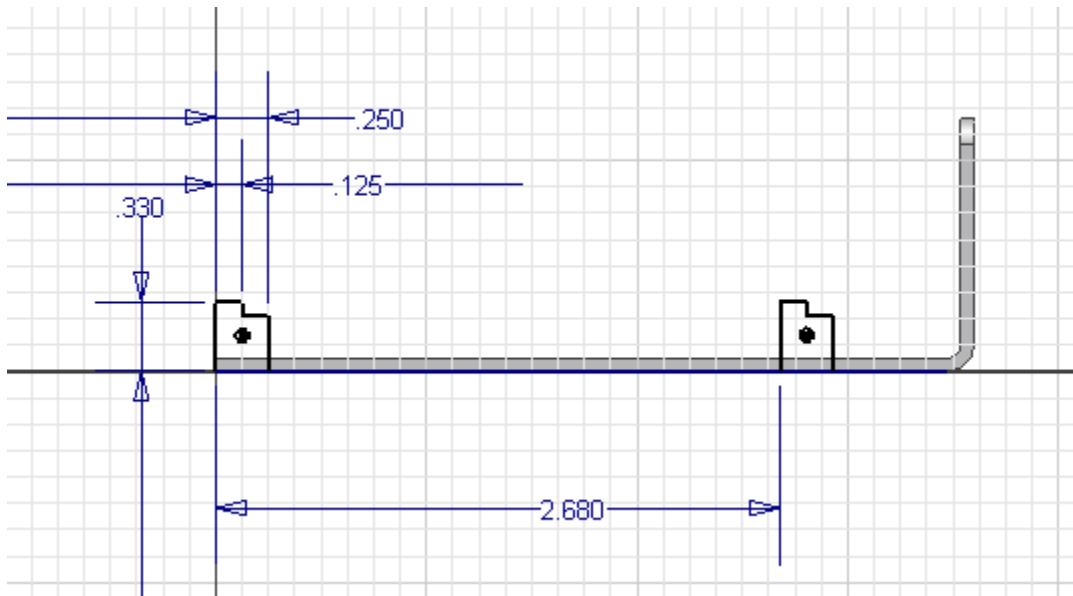

You will have to use Sketch Doctor again to get rid of any missing constraints.

Use the Face tool to create the flanges.

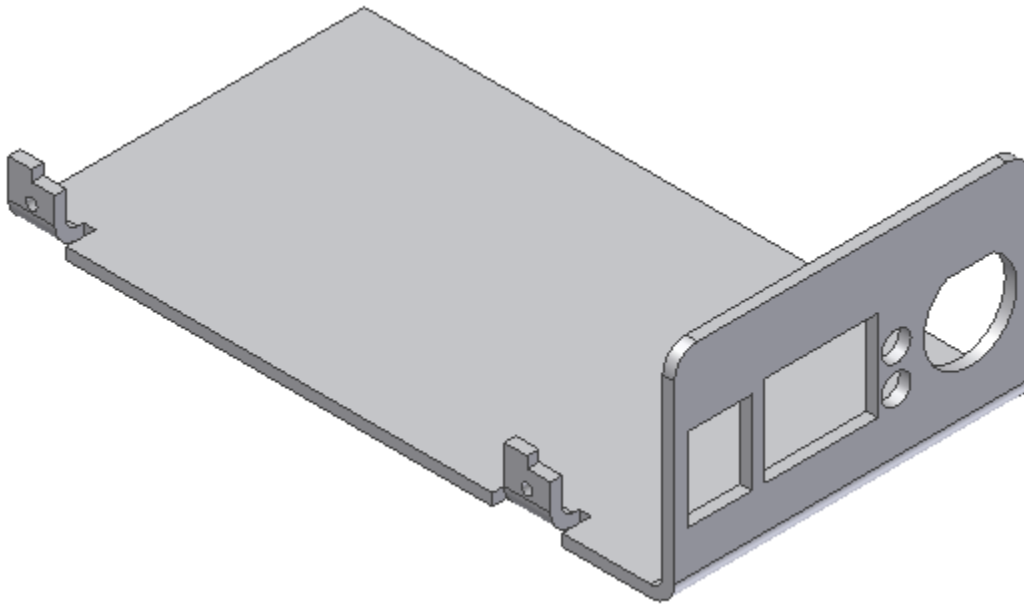

## Going from 2D to 3D in Inventor 5.3

Elise Moss

You can not mirror faces or flanges in Inventor, so you have two choices. You can project the flange geometry to a sketch plane on the other side or you can copy and paste the flange sketch entities to the other side. If you elect the Copy and Paste method, you may have to run Sketch Doctor again to add missing constraints before you can use the Face too.

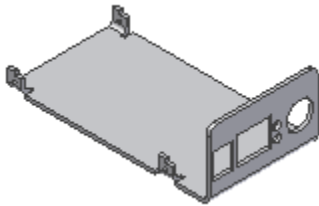

The completed model.

# Going from 2D to 3D in Inventor 5.3

Elise Moss